

Bucket Elevator

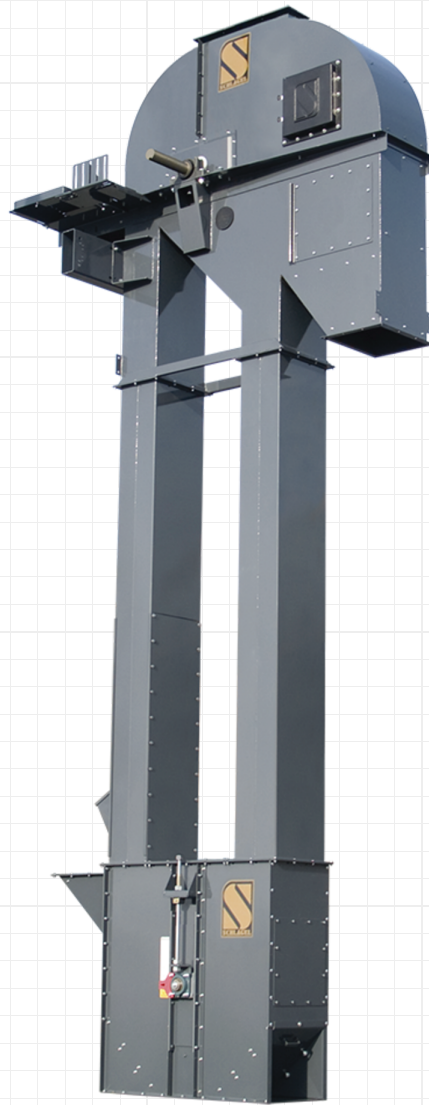

Quality Fabricated Bucket Elevators

Bucket Elevator

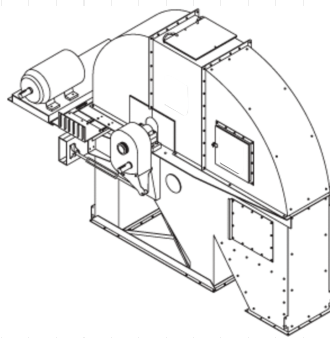

Advantages

- Multi-Layer Anti- Corrosive Coat
- Food Grade Oil Resistant Belt
- Ease of Maintenance
- Easy installation of belt and buckets

Bezalel Belt and Bucket elevator legs compliment our line of handling equipment with performance and quality proven in the industry. As with all our equipment, we guarantee the performance and quality of these legs and design them for high reliability and low maintenance.

The head section is designed and ruggedly constructed to withstand the torque of drive components, maintain alignment and to aid in maintenance. The head pulley is crowned, lagged and mounted on the head shaft with tapered bushings to eliminate side movement. We select bearings to handle severe service with roller bearings standard on larger sizes and provide jack-bolts under the head shaft bearings on all models to allow ease in field shimming for proper belt tracking.

Proper belt tension is easily maintained. Clean-out doors on both ends of the boots are also standard features. Our trunking provides superb dust tight and weather tight protection with continuous jig welded. The operator may also view cup fill through the standard inspection door.

Rubber belt with vented plastic cups is standard. Special belting such as PVC, high temperature or food grade belt is available on request as are steel cast, or nylon cups in non-vented or other venting patterns.

Can be custom designed to meet specific project requirements

Applications : Seeds, Spices, Grains, Pulses, etc

Optional : Stainless Steel Version

Description	UOM	BBE 12	BBE 25	BBE 16	BBE 18
Belt Speed	m/s	1.25	1.5	1.6	1.8
Belt Width	mm	150	250	250	350
Max.Height	m	20	20-25	20-25	20-25
Capacity	m3/hr	8	40	60	80

www.bezalelworks.com

We reserve the right to make technical change or modify the contents of this document without prior notice. The manufacturer reserves the right to make any changes considered necessary for the purposes of improvement at any time or for any reason without prior notice, in its policy of continuous product development and progress.

© Copyright 2019 Bezalel Works. All right reserved.

Bezalel Works
(An Engineering Division of SK Associate)

14/24A, Marutham Nagar, Edyarpalayam, Coimbatore -641025, TamilNadu, India
O: +91 4222406888 M: +91 8754199888 E: mail@bezalelworks.com